

(12) **UK Patent Application** (19) **GB** (11) **2 329 127** (13) **A**

(43) Date of A Publication 17.03.1999

(21) Application No **9819678.5**

(22) Date of Filing **09.09.1998**

(30) Priority Data

(31) **9719520** (32) **12.09.1997** (33) **GB**

(71) Applicant(s)

**KCI Medical Limited
(Incorporated in the United Kingdom)
Two Rivers, Station Lane, WITNEY, Oxfordshire,
OX8 6BH, United Kingdom**

(72) Inventor(s)

**Keith Patrick Heaton
Kenneth William Hunt**

(74) Agent and/or Address for Service

**Brookes & Martin
High Holborn House, 52-54 High Holborn, LONDON,
WC1V 6SE, United Kingdom**

(51) INT CL⁶

A61M 27/00 , A61B 19/08 , A61M 1/00

(52) UK CL (Edition Q.)

A5R RCEA RED

(56) Documents Cited

**GB 0692578 A WO 97/18007 A1 US 5549584 A
US 5437651 A US 5437622 A**

(58) Field of Search

**UK CL (Edition P) A5R RCEA RCEB RED RET
INT CL⁶ A61B 19/08 19/10 , A61M 1/00 27/00
Online: WPI**

(54) Abstract Title

Suction head and drape wound treatment assembly

(57) This invention relates to a drape and a suction head combination for attaching to a wound area. The suction head comprises a planar flange portion and a tubular connector piece on a first face which communicates with an aperture extending to the second face. The second face is formed with projections which define flow channels for facilitating flow of liquids to the aperture. The drape comprising a thin, flexible adhesive-coated plastic film attaches said suction head to the wound area.

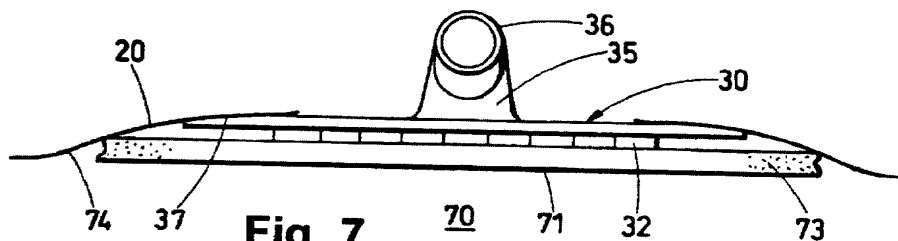

Fig. 7

GB 2 329 127 A

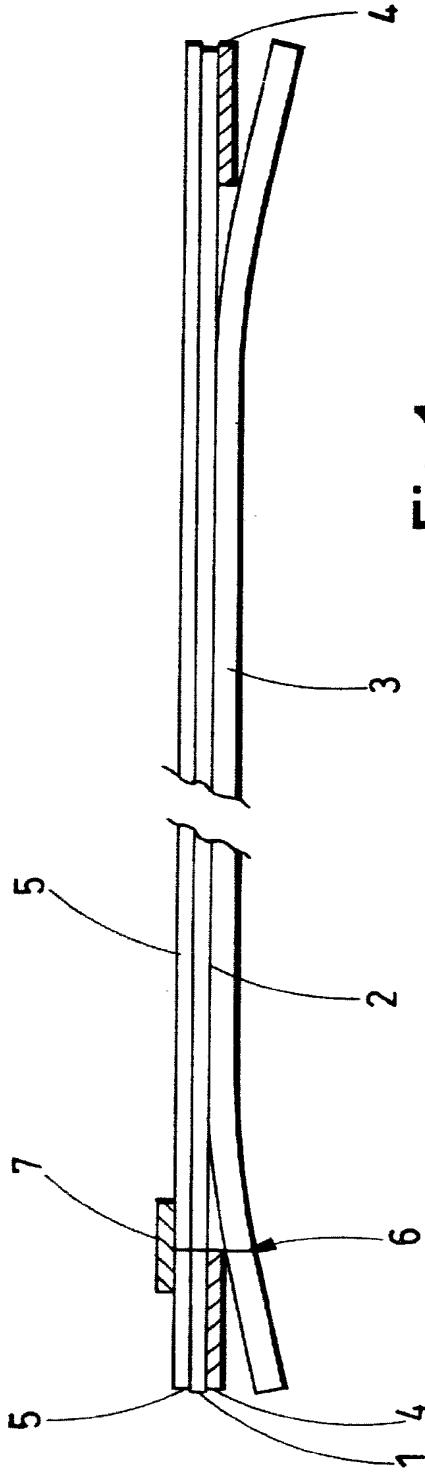

Fig. 1

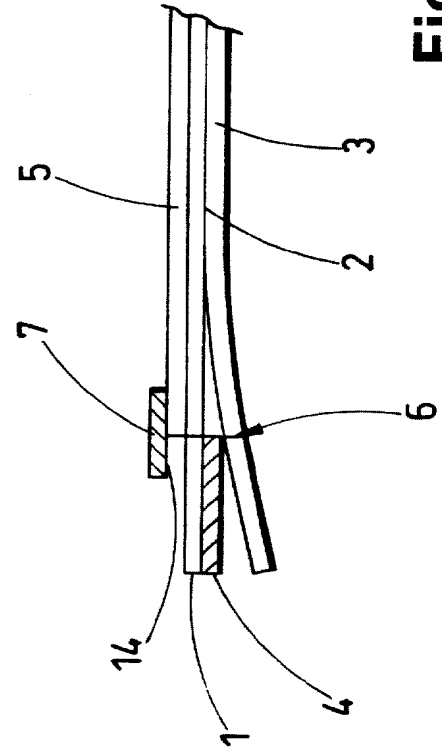

Fig. 2

1000

2/4



Fig. 3

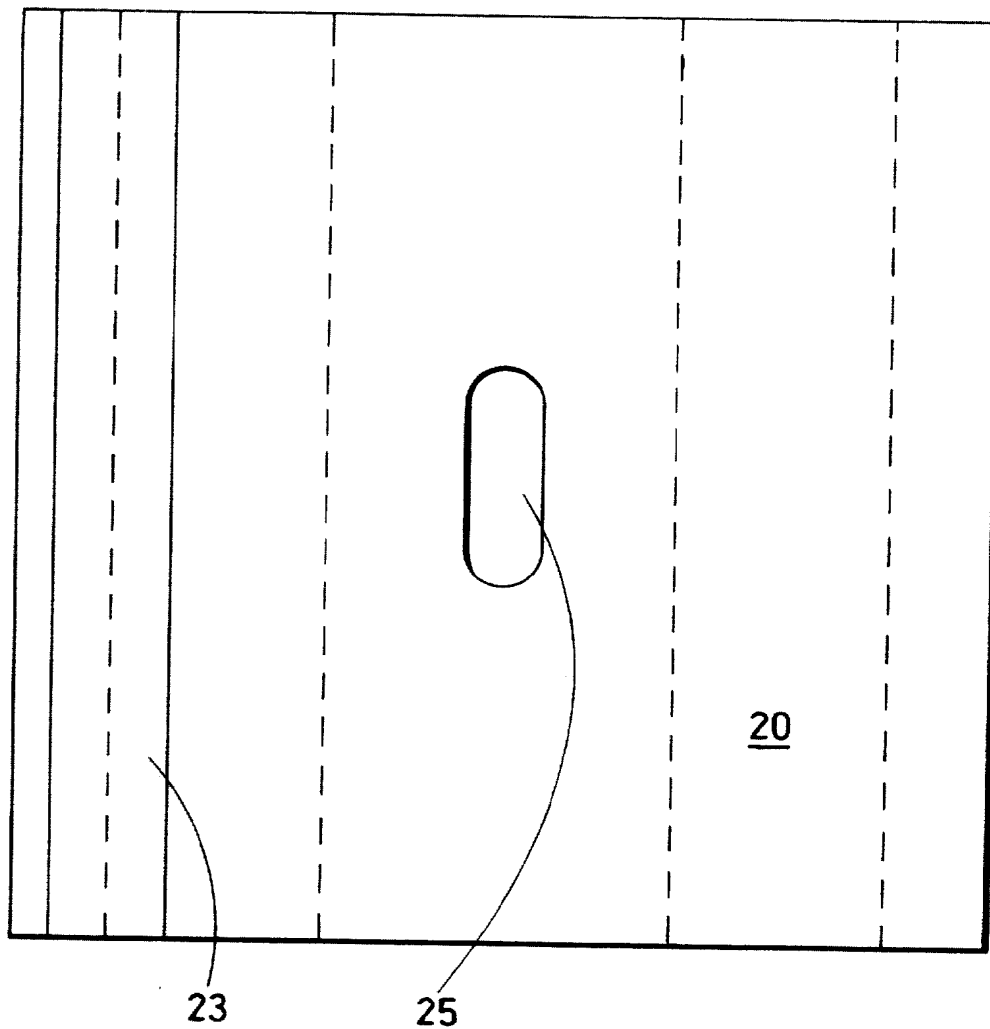

Fig. 4

3/4

3/4

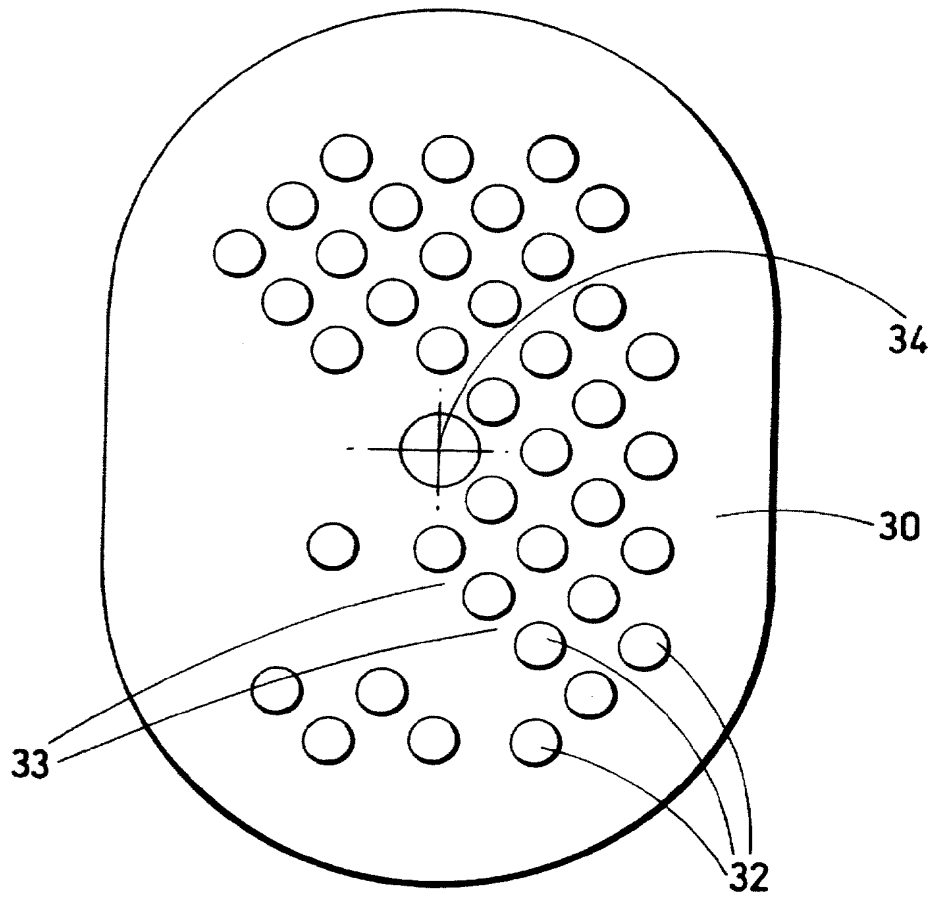

Fig. 5

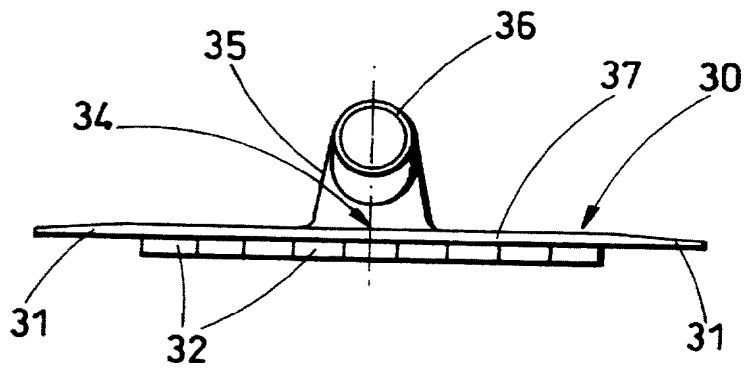

Fig. 6

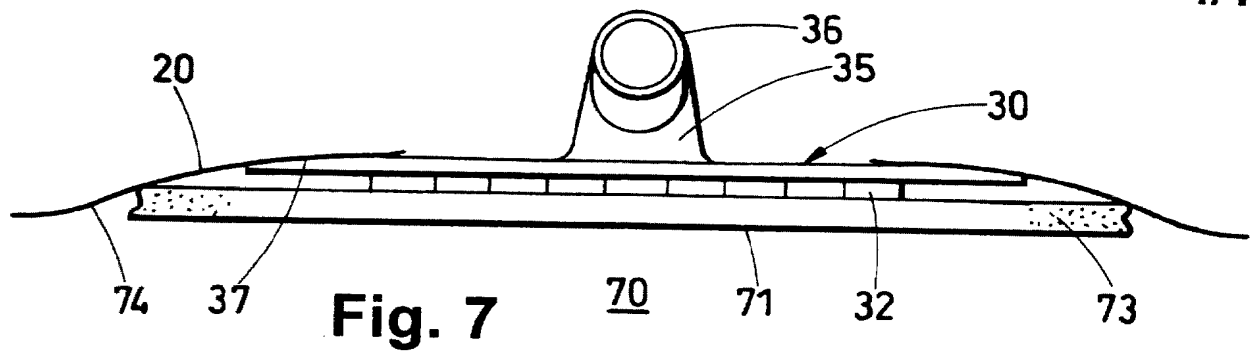

Fig. 7

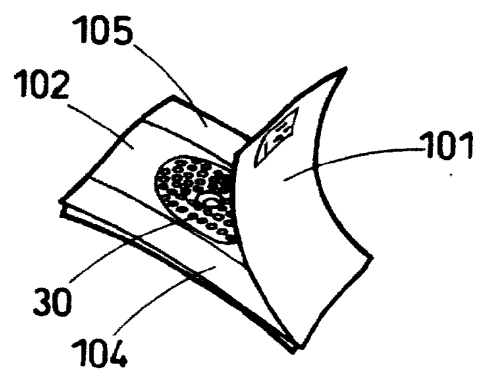

Fig. 8

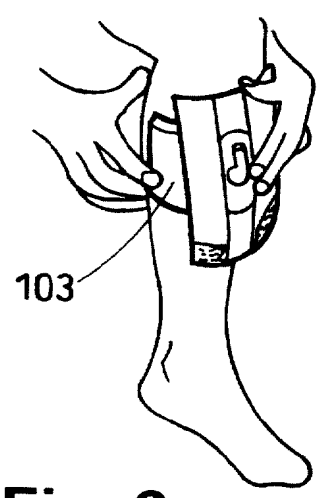

Fig. 9a

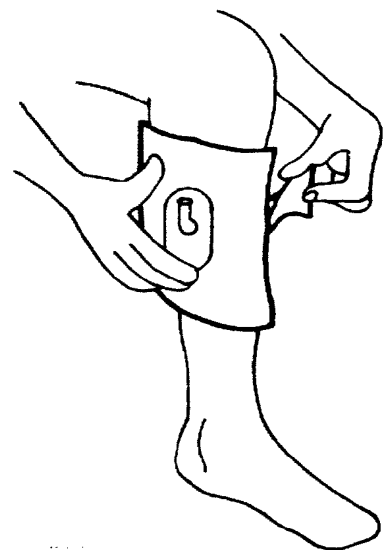

Fig. 9b

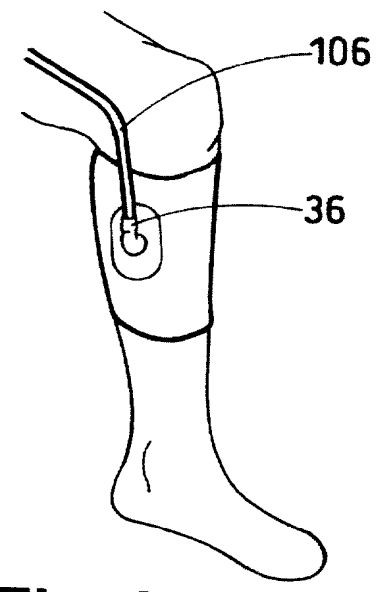

Fig. 9c

Surgical Drape and Suction Head for Wound Treatment

This invention relates to surgical drapes and suction heads for wound treatment.

Surgical drapes are widely used in surgical operations for the purpose of reducing infection and facilitating the handling of skin around incisions. Normally, they are transparent or translucent. Typically, they consist of a flexible, plastics film which is adhesive-coated and which is applied to the area of the operation, prior to making the incision. Surgical drapes are also used for attaching treatment devices to patients after an operation, such as catheters or drainage tubes.

A further, recently developed use is for connecting a suction tube to a wound for the purpose of stimulating healing of the wound. Such use is described in our earlier PCT Applications Nos. WO 96/05873 and WO 97/18007.

Various proposals have been made in the past to design the surgical drape so that handling of the sticky, flexible, plastics film is facilitated. For example, US Patent No. 5,437,622, describes a surgical drape which is a laminate of three materials. The first material comprising a transparent, thin plastics film which is adhesive-coated and this is protected with a layer of release-coated paper. The other face of the adhesive-coated film is strengthened with a reinforcing layer of a less flexible, plastics film. Handling bars or strips are attached to the flexible, plastics film at its lateral edges to facilitate handling of the flexible, plastics film after stripping away the protective releasable layer.

Where it is desired to use a surgical drape primarily to attach a device such as a catheter to a wound area after an operation or for long term treatment, it is inconvenient for the surgeon or nurse to have to adapt a standard surgical drape for this purpose. It would be more convenient to have a surgical drape which was suitable without adaptation to accommodate the treatment device.

One aspect of the present invention is directed to a solution to this problem. A second aspect provides a combined surgical drape and suction head for applying suction to a wound area to facilitate application of negative pressure therapy.

According to one aspect of the present invention there is provided a surgical drape which comprises a thin, flexible, adhesive-coated plastics film and a strengthening layer applied to the face opposite to the adhesive coating, the strengthening layer being a plastics film which is thicker or less flexible than said adhesive-coated film, and a protective, releasable layer applied to the adhesive coating, the drape having an aperture through at least the strengthening and adhesive-coated film to permit, in use, access to a wound area, a first edge of the drape having non-adhesive coated handling bars for separating the adhesive-coated film from the protective layer, and wherein the protective layer comprises a separate strip extending parallel to the first edge of the drape, and which protects the adhesive coating in the region of the aperture and carries a flap overlapping the adjacent portion of the protective layer, said flap constituting a handle for facilitating removal of said strip prior to use. Preferably, non-adhesive-coated handling bars are positioned at opposite lateral edges of the drape.

In practice, surgical drapes may be manufactured by laminating an adhesive-coated flexible film, such as a polyurethane film, to a protective releasable layer, such as a siliconised paper. A strengthening layer of thicker plastics material, e.g. a polyolefin such as polyethylene, may be applied to the non-adhesive coated face of the flexible film, so that a three-layer laminate is produced. These laminates are produced in substantial width and may be slit longitudinally to the desired width and then laterally to form drapes of the desired size.

After slitting to a desired width, handling bars are normally applied to the adhesive-coated layers at one or both lateral edges to facilitate separation of the film

from the protective, releasable layer. While an aperture could be cut at the desired position through the layers to accommodate a catheter or a device such as those described in our above-mentioned applications, it is difficult to handle the highly pliable and adhesive film after the releasable layer has been stripped off.

Although the strengthening layer does somewhat improve the handling characteristics, this is not a complete answer to the problem. However, the handling characteristics are substantially improved by providing a protective layer which is in at least two portions, one of which is in the form of a strip, e.g. one extending parallel to the lateral edges of the drape, and covering the peripheral area around the aperture through the drape. By providing a flap on this portion of the releasable layer, it can be stripped off initially so that the drape is first positioned around the device which is to pass through the aperture, and then the remaining part of the protective releasable layer is stripped off to adhere the drape to the patient's skin around the area to be treated.

In a preferred form of the invention in which negative pressure therapy is applied to a wound area, the surgical drape described above is combined with a suction head having a connector piece which is adapted to be connected to a suction tube. Thus, in this embodiment, the suction head can be adhered to the patient's skin in the area of the wound after removing the strip of protective releasable layer, and then the remaining part of the drape affixed to the patient's skin. In this way, the suction head is held firmly in place and, at the same time, seals the suction head to the wound area and prevents leakage of air from atmosphere into the wound area.

The invention also includes a suction head having a design which facilitates the suction of fluid from a wound area.

According to a further feature of the invention, therefore, there is provided a suction head for applying suction to a wound area which comprises a generally planar

flange portion and a tubular connector piece on a first face, for connecting a suction tube to an aperture through the flange portion to the other face, said other face having projections defining flow channels facilitating flow of fluid towards said aperture.

Preferably, the suction head described above is combined with a surgical drape, the drape comprising a thin, flexible, adhesive-coated plastics film, and the tubular connector piece extends through an opening in the plastics film with the adhesive coating adhered to said first face of the flange portion.

Preferably, the suction head is used in conjunction with an open-celled foam pad so that one surface of the foam pad is placed in contact with a wound area and the suction head applied to the other surface of the foam pad. In the case of deep wounds the foam may be shaped and placed so that it is packed into the wound cavity as described in our above cited PCT applications. According to another technique, which is particularly applicable to superficial wounds, the foam pad may be a relatively thin pad which is placed over the wound. The suction head is placed in contact with the open face of the foam pad and the drape applied over the suction head to fix the assembly to the patient's skin.

Various types of open celled foams can be used as described in our above cited PCT applications. The foam may be a polyurethane foam but polyvinyl acetate (pva) foams are preferred, especially when used as a pad which is placed over the wound. These are to some extent hydrophilic, which seems to exhibit beneficial comfort properties when applied to the skin. Wound healing is stimulated by maintenance of moist conditions in the wound area, and this is facilitated by using a hydrophilic foam.

Further features and advantages of the present invention will be apparent from the following description and accompanying drawings, of non-limiting examples in accordance with the invention.

Referring to the accompanying drawings:-

Figure 1 represents a conventional design of surgical drape;

Figure 2 represents a variation in the design of the handling bars at one end of the drape shown in Figure 1;

Figure 3 is a view similar to Figure 1 of a surgical drape in accordance with the invention;

Figure 4 is a plan view of the surgical drape shown in Figure 3;

Figure 5 is a plan view from beneath of a suction head in accordance with the invention; and

Figure 6 is a side elevation of the suction head shown in Figure 5;

Figure 7 is a view similar to Figure 6 but shows the suction head secured to a skin surface with the drape and with a foam pad located between the head and the skin surface.

Figure 8 is a perspective view of the drape with a central strip portion of the protective sheet in the course of being removed, and

Figures 9(a)~9(c) illustrate the steps of affixing the dressing assembly to a wound area on a patient's leg and attachment to a negative pressure assembly.

Referring to Figures 1 and 2 of the accompanying drawings, a conventional laminate for use as a surgical drape comprises a thin, flexible, transparent plastics film 1 which is adhesive-coated on one face 2, normally with a high-tack pressure-sensitive adhesive, and is protected with a releasable layer 3. The thin plastics film is conveniently of polyurethane because it transmits moisture. Layer 3 is normally considerably thicker than film 1 and is coated on the surface adjacent to the adhesive with a releasable material such as a silicone to facilitate stripping away from the adhesive-coated film.

In order to facilitate removal of the adhesive-coated film prior to use of the device, handling bars 4 are bonded at each end to the adhesive-coated film 1. Thus,

by holding one of the bars 4, the protective layer 3 can be stripped off and the adhesive face applied to the skin of the patient. To facilitate handling of the thin, flexible film 1, a strengthening plastics film 5 is frequently applied to the free face of the plastics film 1. This is generally also transparent or translucent. Film 5 is preferably not bonded with adhesive to film 1, but may remain in contact by reason of electrostatic forces or because of close contact between the two conforming surfaces of film 1 and film 5.

Usually, the surgeon or nurse will wish to strip off the protective layer 5 after the film 1 has been correctly placed on the patient's skin, and this can be facilitated by making partial cuts 6 through the films 1 and 5, so that as the handling bar 4 is drawn upwards from the patient's skin, the adhesive film 1 remains adhered to the patient, while the partial cuts 6 causes separation of the flexible film from the strengthening film 5. Strengthening bars 7 may be provided to hold the lateral edges of the strengthening film 5 and film 1 together with their main parts.

An alternative arrangement is shown in Figure 2, in which the strengthening film 5 is provided with a separate overlapping handling bar 14, to facilitate its removal from the flexible film 1.

Further details of the make-up and manufacture of surgical drapes are given in US Patent No. 5,437,622 and European Patent Application No. 0161865 and the prior art referred to therein, the disclosure of which is incorporated herein.

Referring to Figure 3 and 4, the surgical drape of this invention comprises a protective outer film 20, laminated to a thin, flexible film 21. The flexible film 21 includes an adhesive-coated layer which is protected with a release-coated sheet material 24. Lateral edges of the flexible film 21 are provided with handling bars 23. Thus far, the design is essentially the same as that shown in Figures 1 and 2.

The drape of the present invention differs from the drape shown in Figures 1 and 2 in that an aperture 25 is cut through the strengthening layer 20 and through the flexible layer 21. The other difference compared with the prior art drapes is that the protective releasable layer is formed in at least two sections.

In the embodiments shown in Figures 3 and 4, the central portion of the releasable layer comprises a strip 26, having flaps 27 which overlap the remaining outboard portions of the releasable layer. The purpose of this is to enable the central strip 26 to be removed first, without disturbing the remaining portions of the releasable layer. The drape can then be fitted around the wound area and, if desired, a suction device or other treatment device passed through the aperture 25 and secured to the patient's skin with the peripheral areas of exposed adhesive-coated film.

An example of a device for applying suction to the wound area is illustrated in Figures 5, 6 and 7.

Referring to these Figures, the suction head comprises a flange portion 30 having a tapered edge 31, and a profile which may be of any desired shape but is generally rounded at its edges. On the face of the flange 30 intended for contact with the patient's skin or a foam pad are formed a series of projections 32 which are distributed over the surface of the flange apart from the peripheral edge portion 31. The purpose of these projections is to provide fluid channels 33 facilitating the flow of fluids from any point of the flange to a central point 34, from which it is intended to apply suction. The suction head includes a connector 35, located above the aperture 34, having a tubular end 36 adapted for receiving and connecting a catheter. The tubular end may have an outwardly tapered portion to facilitate feeding a catheter into the connector. The upper surface 37 of the suction head has a substantially smooth surface.

In use, the connector portion 35 is sized so that it extends through the aperture 25 in the surgical drape shown in Figures 3 and 4, with the adhesive surface around the aperture bonded to the smooth surface 37 of the flange 30. The suction head may be packaged in this condition with the surgical drape so that in use, the strip 26 is removed by pulling on the handles 27 thus exposing the adhesive surface in the vicinity of and surrounding the suction head. The suction head can then be fixed in the desired position on the patient's wound and then the remaining portion of the protective film removed to fix the drape to the patient. The flange 30 of the suction head may be somewhat oval as shown in Figure 5, and have dimensions as indicated in this Figure, i.e. a longer dimension of about 95mm and a short dimension of about 70mm. Alternatively, the flange may be circular and be smaller in plan view. For example, the diameter of a circular suction head may be from about 30 to 50mm in diameter, e.g. about 40mm. It has been found that the suction head flange should not overlap the area of the wound. Thus, in the case of smaller wounds a smaller suction head is indicated.

Figure 7 shows the suction head attached to a wound area 71 of a patient 70. The suction head is pressed into firm contact with a flexible, open-celled foam 73, which is itself pressed into contact with the wound area 71. The suction head and foam pad are pressed into contact with the wound area by a surgical drape 20 having an adhesive surface 74. The adhesive surface is bonded to the patient's skin outside the periphery of the foam pad and suction head. It is also bonded to the upper surface 37 of the suction head. An aperture is formed in the drape to permit the connector portion 35 to extend upwardly through the drape. In order to avert the danger of incorrect catheter tubes being fitted to the connector 35, the latter may have a customised cross-section or internal projection such as a rib or key which co-operates with a corresponding slot or key way in the catheter. Alternatively, the catheter may

be moulded with a projection or longitudinal rib which co-operates with a corresponding slot or key way in the aperture of the connector 35.

The foam pad may be packaged in a plastic pouch, sterilised by gamma irradiation and supplied in the same box or in other packing units as the suction head and drape.

Figures 8 and 9(a)-(b) illustrate the way in which the drape/suction head combination is fitted to a wound on a patient's skin. In Figure 8, a backing sheet 101 having a release coated surface is removed in the first step from the adhesive face 102 of the drape to expose the face of the connector 30. A pad 103 of foam is positioned over the wound area and the drape placed over the foam pad, the drape being adhered to the skin above and below the pad (Figure 9a). The lateral protective strips 104 and 105 are removed in turn from the drape and the assembly adhered to the skin (Figures 9(b) and 9(c)). Finally, the spout 36 is connected to a tube 106 which is then connected to a source of suction, e.g. a pump as described in our above PCT application, in order to apply negative pressure to the wound. The suction head and drape assembly is shown in Figure 8, with the smooth surface 37 adhered to the drape, is conveniently packaged in an easily openable plastic bag or pouch, and sterilised for immediate use.

CLAIMS:-

1. A suction head for applying suction to a wound area which comprises a generally planar flange portion and a tubular connector piece on a first face for connecting a suction tube to an aperture through the flange portion to the other face, said other face having projections defining flow channels for facilitating flow of fluids to said aperture.
2. A suction head as claimed in claim 1 which is combined with a surgical drape, the drape comprising a thin, flexible adhesive-coated plastics film, the tubular connector piece extending through an opening in the plastics film with the adhesive coating adhered to said first face of the flange portion.
3. A suction head and surgical drape combination as claimed in claim 2 in which the adhesive-coated film is strengthened with a second plastics film which is thicker or less flexible than said adhesive coated film.
4. A suction head and surgical drape combination as claimed in claim 2 or 3 wherein the adhesive coating on said flexible film is protected with a protective, releasable layer covering the area of the adhesive, said releasable layer comprising a separate strip protecting the adhesive coating in the vicinity of the suction head and said strip carrying a flap overlapping an adjacent portion of the releasable layer and constituting a handle to facilitate removal of said strip prior to use.
5. An assembly for use with a source of suction for stimulating healing of wounds which comprises a foam pad comprising an open-celled flexible polymer foam and a suction head and drape as claimed in claim 4
6. A surgical drape which comprises a thin, flexible, adhesive-coated plastics film and a strengthening layer applied to the face opposite to the adhesive coating, the strengthening layer being a plastics film which is thicker or less flexible than said adhesive-coated film, and a protective, releasable layer applied to the

adhesive coating, the drape having an aperture through at least the strengthening film and adhesive-coated film to permit, in use, access to a wound area, at least one first edge of the drape having a non-adhesive coated handling bar for separating the adhesive-coated film from the protective layer, and wherein the protective layer comprises a separate strip extending parallel to the first edge of the drape, and which protects the adhesive coating in the region of the aperture and carries at least one flap overlapping the adjacent portion of the protective layer, said flap constituting a handle for facilitating removal of said strip prior to use.



Application No: GB 9819678.5
Claims searched: 6

Examiner: Craig R. Thomson
Date of search: 18 January 1999

Patents Act 1977
Further Search Report under Section 17

Databases searched:

UK Patent Office collections, including GB, EP, WO & US patent specifications, in:

UK Cl (Ed.Q): A5R (RED)

Int Cl (Ed.6): A61B 19/08

Other:

Documents considered to be relevant:

Category	Identity of document and relevant passage	Relevant to claims
A	GB 692578 (MINNESOTA MINNING) see especially p1, lines 18-41, p4, lines 38-59 and figure 4.	6
A	US 5437622 (CARION) see especially column 2, lines 20-37 and figure 1.	6

X	Document indicating lack of novelty or inventive step	A	Document indicating technological background and/or state of the art.
Y	Document indicating lack of inventive step if combined with one or more other documents of same category.	P	Document published on or after the declared priority date but before the filing date of this invention.
&	Member of the same patent family	E	Patent document published on or after, but with priority date earlier than, the filing date of this application.